

TEMPLE ALLEN INDUSTRIES EMMA SURFACE PREPARATION SYSTEMS

# EMMA ROLLING STAND SYSTEM

ACCESS FROM FLOOR TO 12' HIGH

*Mechanical Sanding, Grinding, and Polishing  
Solutions that protect workers and  
boost productivity*



## Measurable Gains In Productivity:

- ✓ 4 - 7 times faster
- ✓ Sand 5x longer before changing paper
- ✓ Experience virtually dustless operations

## Enhanced Safety - Top of Plane to Bottom Line:

- ✓ Eliminates vibration and high grip force trauma
- ✓ No more sore shoulders or aching backs
- ✓ Boosts worker health, morale, and availability
- ✓ Captures particulates, keeps shop air cleaner

## Quality You Can Touch, See, And Measure:

- ✓ Consistently higher quality surface
- ✓ Reduces scrapped parts and scalloping damage

## Simplifies Workflow & Operations:

- ✓ Requires few modifications to the existing workflow
- ✓ Available with integrated Nilfisk vacuum systems
- ✓ All-pneumatic, no electricity
- ✓ 97% or better availability

## Rolling Stand Access Zones

### Commercial Aircraft

Zone 1 - Under Wings, Engine Cowlings

Zone 2 - Under Belly

### Business and Personal Aircraft

Zone 1 - Under Wings, Engine Cowlings

Zone 2 - Fuselage Sides

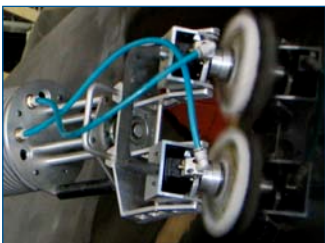



Vertical 24" sliding columns



360° Rotating Turntable



Vertical Sanding reaching down



Vertical Sanding reaching up

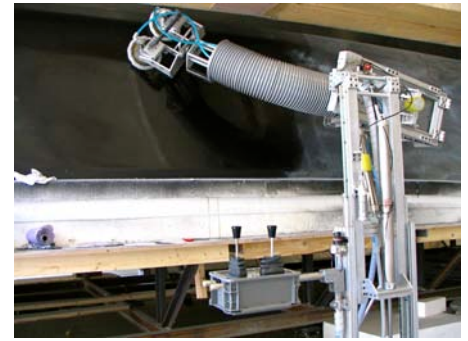

**Temple Allen EMMA Stand System**

EMMA Arm length .....	27 inches
System footprint .....	41.5" x 40"
EMMA sweep width .....	4 feet
Vertical Surface Access .....	0.5' - 8.5'
Horizontal Access .....	50" - 110"
System Height (low) .....	69 inches
Stand Vertical Raise .....	24 inches
Stand Pitch adjustment .....	90°
Auto Adjustment Range .....	14 inches
Sander Capacity .....	1, 2, or 3
Air requirement (90 psi) .....	5 cfm
Sander Air req. (cfm) .....	12 (typical)
Vacuum Air req. (cfm) .....	30 (typical)
Vacuum Airflow (cfm) .....	99
Vacuum Filtering .....	99.97%
<i>note - Custom systems available - call us.</i>	

The EMMA Rolling Stand System performs sanding operations either overhead or sideways, and can roll independently along the floor or take guidance from a rail, track, or part dolly.

The EMMA Rolling Stand is part of a complete solution to numerous sanding challenges. Just picking a sander and a paper is not enough anymore. Operations today require faster processes, better safety, lower costs, and a dust-free shop.

Temple Allen has you covered.

*Auto-Adjust feature guarantees sanding at exactly the pressure you specify*

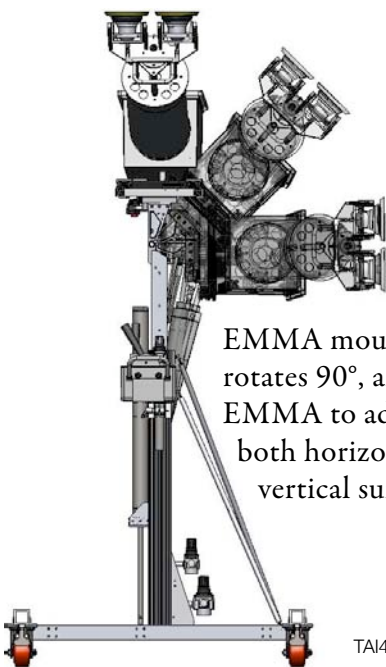

EMMA mounting rotates 90°, allowing EMMA to address both horizontal and vertical surfaces

TAI4522 Rev A

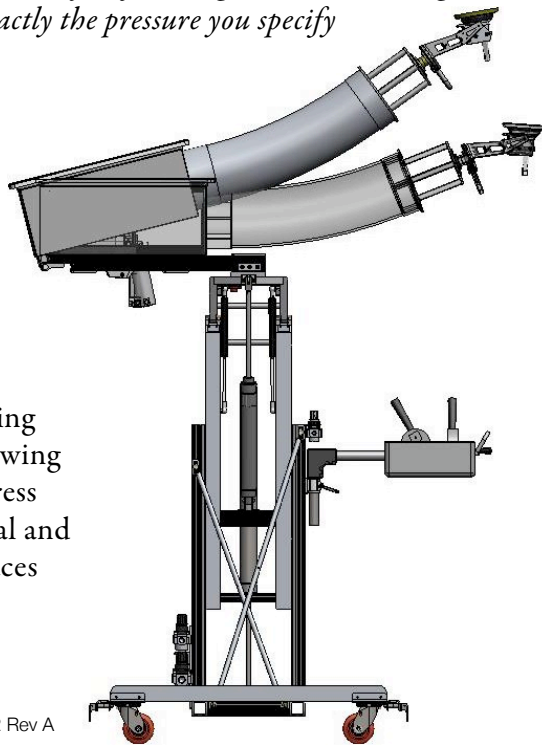

*EMMA integrates with optional Nilfisk A15 Vacuum System and Norton "Multi-Air" Abrasives*

