

TEMPLE ALLEN INDUSTRIES EMMA SURFACE PREPARATION SYSTEMS

# EMMA OVERHEAD RAIL SYSTEM

FRAME, JIB CRANE, OR CEILING-MOUNTED DEPLOYMENTS

*Mechanical Sanding, Grinding, and Polishing  
Solutions that protect workers and  
boost productivity*

## Measurable Gains In Productivity:

- ✓ 4 - 7 times faster
- ✓ Sand 5x longer before changing paper
- ✓ Experience virtually dustless operations

## Enhanced Safety - Top of Plane to Bottom Line:

- ✓ Eliminates vibration and high grip force trauma
- ✓ No more sore shoulders or aching backs
- ✓ Boosts worker health, morale, and availability
- ✓ Captures particulates, keeps shop air cleaner

## Quality You Can Touch, See, And Measure:

- ✓ Consistently higher quality surface
- ✓ Reduces scrapped parts and scalloping damage

## Simplifies Workflow & Operations:

- ✓ Requires few modifications to the existing workflow
- ✓ Available with integrated Nilfisk vacuum systems
- ✓ All-pneumatic, no electricity
- ✓ 97% or better availability



## Overhead Rail Ideal Applications

### Ceiling Mounts - Linear Rails

Zone 1 - Prep Booths, Finishing Shops

Zone 2 - Assembly Areas

### Ceiling Mounts - X-Y Rails

Zone 1 - Prep Booths, Finishing Shops

Zone 2 - Assembly Areas

### Table Mounts

Zone 1 - Panels and Parts

### Jib Crane Mounts

Zone 1 - Engine Cowlings, Fan Collars



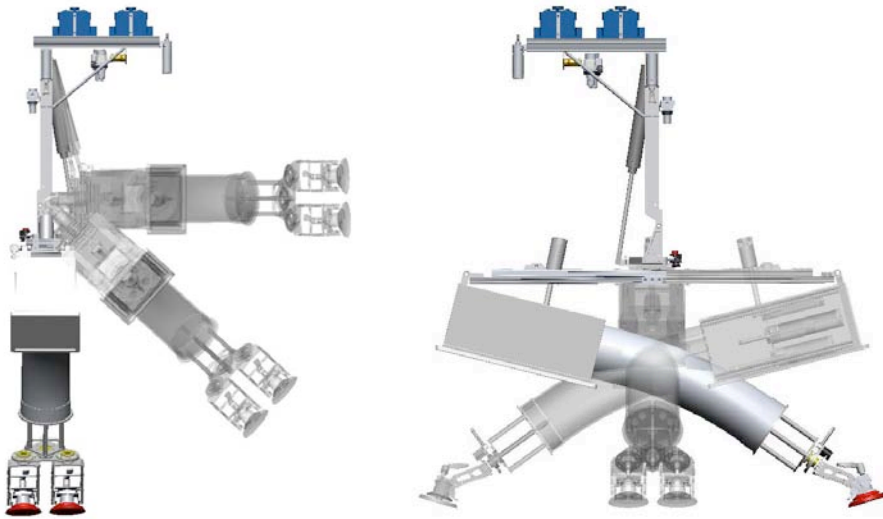

*EMMA mounting rotates 90° in one plane (left), and 360° in the other (right), allowing EMMA to address both horizontal and vertical surfaces*

EMMA Overhead-mounted Rail Systems are part of a complete solution to numerous sanding challenges. Just picking a sander and a paper is not enough anymore. Operations today require faster processes, better safety, lower costs, and a dust-free shop. Temple Allen has you covered.

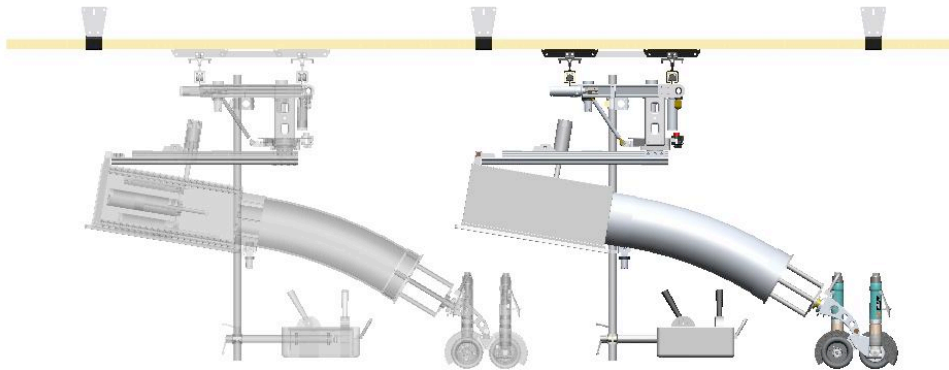
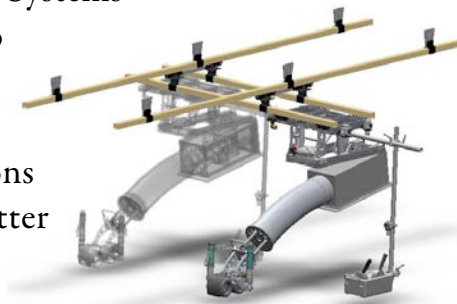

**EMMA Overhead Rail System**

- EMMA Arm length ..... 27 inches
  - EMMA sweep width ..... 4 feet
  - Vertical Surface Access ..... task specs'
  - X-Y Frame Range ..... task specs
  - Rail Length ..... task specs
  - Unit Vertical Raise ..... task specs
  - Unit Pitch adjustment ..... task specs
  - Auto Adjustment Range ..... 14 inches
  - Sander Capacity ..... 1, 2, or 3
  - Air requirement (90 psi) ..... 5 cfm
  - Sander Air req. (cfm) ..... 12 (typical)
  - Vacuum Air req. (cfm) ..... 30 (typical)
  - Vacuum Airflow (cfm) ..... 99
  - Vacuum Filtering ..... 99.97%
- note - Custom systems available - call us.*



*EMMA integrates with optional Nilfisk A15 Vacuum System and Norton "Multi-Air" Abrasives*



TAI4523 Rev A